



Design of industrial load management using automatic control with ZigBee wireless technology

Pratiksha Bhusari, Rahul Khetre, Rajesh Kumar, Manoj Meshram, Sachet Shambharkar

*Department of Electronics and Communication Engineering,
Tulsiramji Gaikwad-Patil College of Engineering Technology, Nagpur*

Prof. Sneha Padole

*Assistant Professor Department of Electronics and Communication Engineering,
Tulsiramji Gaikwad-Patil College of Engineering Technology, Nagpur*

Abstract— Today's world is facing deficiency of getting the regular power. In order to cope up with this demand load shedding is done. This paper presents the solution to overcome/limit the problems regarding power contingencies, load shedding, failure in providing sufficient power towards the load center, etc. by distributing the load in three categories low, medium, high. This paper contains the controller which is used to check the load demand and as per set value it will turn on/off the load. In this paper the ZIGBEE is used for data transmission as well as communication between transmitter and receiver as per IEEE 802.15.4 Standard. The controller is programmed in such a way that, the supply to load will never be zero. To overcome the problem of power distribution this paper provides an overview of wireless sensor network by managing the equal power distribution by using Zigbee network sensor.

Keywords- Zigbee Wireless sensor unit, Load Management, AT89C52, Relay.

Instead of cutting the power supply we can use the power in such a way that only the low power devices like tubes, fan and TV which are primary needs should be allowed and high power devices like heater, pump-set, iron etc. should not be allowed for that particular period. To achieve this we differentiate the load in low, medium and high power capacity. The AT89C52 microcontroller is the control unit of the system. It control the switching and disconnecting the power supply with sufficient time delay. In this system we using automatic load control means we set the limit of power unit consumption for high, medium and low load. If power demand is increases beyond set limit the Zigbee gives the control signal to the microcontroller and it disconnect automatically the particular load from supply and rest of two is in continuous operation mode. We create a wireless sensor network having number of nodes which Communicate with each other in full duplex mode. The one Zigbee is placed on load side and another connected to the pc side.

I. INTRODUCTION

In recent days, many developing countries like India are facing the problem of shortage of electricity as well as reliability in power towards load centre. The peoples are not getting the basic need of lights, fans, TV etc. It is observed that the existing production capabilities will fails to meet the power demand from the various sectors. In nearly every country, researchers expect existing energy production capabilities will fail to meet future demand without new sources of energy, including new power plant construction [1]. In many countries the increase in demand is growing at a faster rate than transmission capacity and also the cost of providing power is also increasing due to the higher coal prices and deficiency of fuel. The growing population of countries also one of the reason of not getting the full power to consumers side. So it is necessary to manage the power distribution among the different load to the consumer's side. Nowadays to manage the available power the power is cut for the particular area and the whole area is goes into the dark.

The main purpose of the Zigbee is the communication which consist of data transfer, controlling node operation. We are using Zigbee protocol for the wireless communication. The main advantage of using Zigbee protocol is that the nodes require very less amount of power so it can be operated from battery [2]. And in this way we have managing the available power by using wireless sensor network working on Zigbee protocol. Each node is measuring the power, which is being consumed by the appliance. An overall operation of the system controlled by the control device. Main purpose of the project is that the wireless sensor network will differentiate and control the devices in the network on the basis of power consumed by appliances to make the efficient use of power. The basic parts of the project include a Control Unit, End Device Unit having Zigbee interface, Relay.

II. PROPOSED SYSTEM

In case of conventional system, the whole system load is supplied with help of only single feeder. When such system is subjected to increase in the load demand, the system is unable to support that increase in load demand which results into total loss of power and system become unbalance and system fails to support continuity of supply. In proposed system, the distribution of load takes place into three sections which are given as: Low, Medium and High load. For such load, three separate feeders are provided in order to supply load [1]. The feeders are classified as follows,

1. Low load feeder for supplying low or light load.
2. Medium load feeder for supplying medium load.
3. High load feeder for supplying high load.

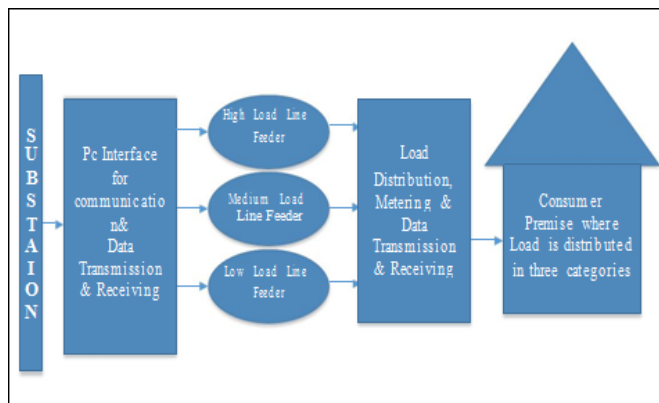

Fig.1 Concept Diagram of Load Management System

Each feeder has its own specified limit of current. These parameters are specified through PC. When any particular sectional load of proposed system is subjected to increase in the load, the feeder of that particular section will carry more current beyond its specified limit in order to support increased load demand. As each feeder has its own specified limit of current, which will disconnect that particular feeder from the system. Hence load on generator side reduces. Now consumer side is supplied with remaining two feeders.

A. Implementation

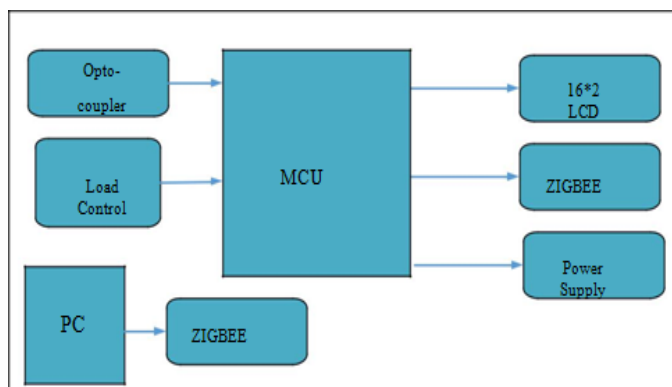

Fig.2 Block Diagram of Proposed System

1) POWER SUPPLY REQUIREMENT:

Circuit will operate on 5 V DC 1A current, so total power required is 5W. Power supply contains step down transformer, bridge rectifier with capacitor filter, lm7805 to get constant supply.

2) DISPLAY:

16x2 line LCD is used to display the data.

3) PERSONAL COMPUTER:

Data will also be send to PC for analysis or record. So MAX 232 IC & RS 232 CABLE is used to interface PC with microcontroller.

4) MICROCONTROLLER:

AT 89C52 microcontroller is used. It is heart of the project. All the process will carried out by this IC. Main program for process will be in this chip.

5) ZIGBEE MODULE:

For transmitting & receiving data to & from central unit.

6) RELAYS:

Relay sense incremental change in specified input data and gives the tripping signal to PC.

III. CONTROL UNIT

It is the heart of system. All the controlling functions, data transmitting/receiving function are done by this unit. Following functions will be carried out by microcontroller unit.

- Receive the set point for load from MSEB server via ZIGBEE.
- Take the pulse from energy meter and calculate the wattage/power consumed.
- To decide which load to switch as per set point.

Here MSEB will decide the maximum power to be supplied to consumer also on what time. The power & time will be configured at MSEB server & server will send the set point to consumer side via ZIGBEE communication. At receiver side or consumer side information of set point will be received. Microcontroller AT89c52 will track load consumed and compare with set point and decide which channel to switch low, medium or high [3]. The AT89C52 provides the standard features such as, 8K bytes of Flash, 256 bytes of RAM, 32 I/O lines, three 16-bit timer/counters, a six-vector two-level interrupt architecture, a full duplex serial port, on-chip oscillator, and clock circuitry. In addition, the AT89C52 is designed with static logic for operation down to zero frequency and supports two software selectable power saving modes. The Idle Mode Stops the CPU while allowing the RAM, timer/counters, serial port, and interrupt system to continue functioning [4]. The Power down Mode saves the

RAM contents but freezes the oscillator, disabling all other chip functions until the next hardware reset.

IV. ZIGBEE CC2500 MODULE

Zigbee was developed by the Zigbee Alliance, a world-wide industry working group that developed standardized application software on top of the IEEE 802.15.4 wireless standard [5]. The power measurement application comprehend many services and appliances within the home and workplace, all of which need to be able to communicate with one another bidirectional. Zigbee also provides strong security capabilities to prevent mischief, and is extremely tolerant of interference from other radio devices, including Wi-Fi and Bluetooth. Zigbee can enabled meters form a complete mesh network so they can easily communicate with each other and route data reliably. And the Zigbee network can be easily expanded as new homes are built or new services need to be added. In this project ZIGBEE CC2500 is used as a media for communication between quad-rotor & server. ZIGBEE uses RF link with carrier frequency 2.4 GHz. It is bidirectional with data anti-collision protection.

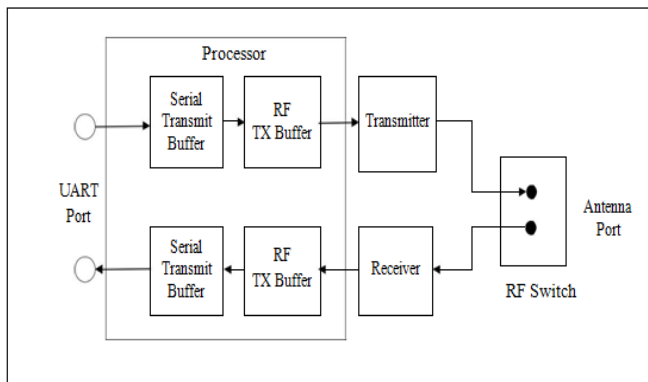

Fig.3 Zigbee CC2500 Module

V. CONCLUSIONS

It is apparent that the present trend of load growth outstripping transmission will continue for the foreseeable future. In order to maintain power system stability, when system is subjected to contingencies introduced by this load/transmission imbalance, protection engineers are challenged to find alternative solutions such as an Intelligent Automatic Load Control to fill the gaps. A set of technologies exist to meet the needs for today and developments are progressing that promise to bring more sophisticated tools. In many countries the increase in demand is growing at a faster rate than transmission capacity and also the cost of providing power is also increasing due to the higher coal prices and deficiency of fuel. To overcome the problem of power distribution this paper provides an overview of wireless sensor network by managing the equal power distribution by using Zigbee network sensor. This paper also shows the ZIGBEE technology for recent communication medium. Zigbee's wireless open standard technology is being selected around the world as energy management technology of choice.

REFERENCES

- [1] Rajesh V. Sakhare, B.T. Deshmukh " On Electric Power Management Using Zigbee Wireless Sensor Network" ,International Journal Of Advances In Engineering And Technology, Vol.4, Issue 1, pp.492-500 July 2012. ISSN:2231-1963.
- [2] J. Han, H. Lee, K.-R. Park, Remote-controllable and energy-saving room architecture based on ZIGBEE communication, IEEE Transactions on Consumer Electronics 55 (1) (2009) 264-268
- [3] Takeshi N (2006). "An Electric Power Energy Monitoring System in Campus using an Internet". Member ,IEEE.83(7):705-722
- [4] Jivan SP, Shelake VG, Kamat RK, Naik GM (2002). "Exploring C for microcontrollers" ISBN 987-1-4020-8392:4-5.
- [5] Rozeha A. Rashid, Hong Ling Zhen. "Wireless Monitoring System Using ZIGBEE IEEE 802.15.4 Standard", Int'l Wireless Telecommunication Symposium (IWTS06), Grand Bluewave Hotel, Shah Alam, 15-17th May 2006.
- [6] K.-C. Lee, H.-H. Lee, "Network-based fire-detection system via controller area network for smart home automation", IEEE Transactions on Consumer Electronics 50 (4) (2004) 1093-1100.
- [7] Zigbee: "Wireless Control That Simply Works" William C. Craig, Program Manager Wireless Communications, ZMD America, Inc.