

Low Power Single Phase Clock Multiband Flexible Divider Using Low Power Techniques

Mr. Devendra O. Rapelli(Author1)
Electronics Engineering Department,
PCE College Nagpur, Maharashtra, India
devend.rapelli@gmail.com

Mrs. Divya Meshram (Author2)
Electronics Engineering Department,
PCE College Nagpur, Maharashtra, India
divyameshram@gmail.com

Abstract- : In this paper, a low-power single-phase clock multiband flexible divider for Bluetooth, Zigbee, and IEEE 802.15.4 and 802.11 a/b/g WLAN frequency synthesizers is proposed based on pulse-swallow topology and is implemented using a 0.18 μ m CMOS technology. The multiband divider consists of a proposed wideband multimodulus 32/33/47/48 prescaler and an improved bit-cell for swallow(S) counter and operates in 2.4 to 5 GHz resolution selectable from 1 to 25 MHz. In this paper, we propose a new method to reduce static power in the CMOS VLSI circuit using Low power Techniques like Sleep Transistor Approach.

Keywords- DFF, E-TSPC, true single-phase clock (TSPC), wireless LAN (WLAN).

I. INTRODUCTION

For mobile wireless communications, low-power operations are of crucial importance for the mobile units as the battery lifetime is limited by the power consumption and the low power consumption also helps to reduce the operating temperature resulting in more stable performance. For the modern transceiver architecture, a fully integrated frequency synthesizer with low power voltage-controlled oscillators (VCO) for quadrature signal generation and low power frequency dividers with multi-channel selection is always a topic of interest in research.

Phase-locked loops (PLLs) are widely used in radio frequency synthesis. The PLL based frequency synthesizer is one of the key building blocks of an RF front-end transceiver. The PLL frequency synthesizer system is mainly designed to ensure the accuracy of its output frequency under operating conditions. The IEEE 802.15.4 standard has been specifically designed to cater for the needs of low cost, low power, low data rate and short range wireless networks. Few frequency synthesizers based on this standard have been reported in

literature and the frequency synthesizer reported in [5] has the power consumption of 2.4 mW at 1.2-V power supply. In the previous design [1], a dynamic logic multiband flexible integer-N divider based on pulse-swallow topology is proposed which uses a low-power wideband 2/3 prescaler [4] and a wideband multimodulus 32/33/47/48.

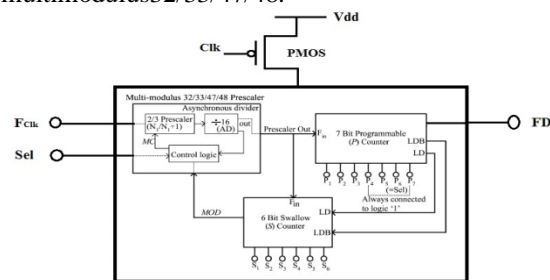

Figure.1. Proposed dynamic logic multiband flexible divider using SleepyP transistor

In this paper a new method for designing a dynamic logic multiband flexible integer-N-divider has been proposed which was developed using a sleep transistor based and wideband multimodulus 32/33/47/48 prescaler with low-power wideband 2/3 prescaler and an integrated S counter as shown in Fig. 1. A sleep transistor is referred to either a PMOS or NMOS high V_{th} transistor that connects permanent power supply to circuit power supply which is commonly called “virtual power supply”. The sleep transistor is controlled by a power management unit to switch on and off power supply to the circuit.

II. DESIGN CONSIDERATIONS

In the case of high-speed digital circuits propagation delay and power consumption are the important

parameters. The maximum operating frequency of a digital circuit is given by,

$$F_{max} = \frac{1}{tpLH + tpHL} \quad (1)$$

The tpLH and tpHL denote the propagation delays of the low- to-high and high-to-low transitions of the gates, respectively. The CMOS digital circuits total power consumption is determined by the switching and short circuit power. The switching power is linearly proportional to the operating frequency and is given by the sum of switching power at each output node as in

$$P_{switching} = \sum_{i=1}^n F_{clk} C_{Li} V_{dd}^2 \quad (2)$$

Where n is the number of switching nodes, fclk is the clock frequency, CLi is the load capacitance at the output node of the ith stage, and Vdd is the supply voltage. Normally, the short-circuit power occurs in dynamic circuits when there exists direct paths from the supply to ground which is given by

$$P_{sc} = I_{sc} * V_{dd} \quad (3)$$

Where Isc is the short-circuit current. The short-circuit power is much higher in E-TSPC logic circuits than in TSPC logic circuits. However, TSPC logic circuits exhibit higher switching power compared to that of E-TSPC logic circuits due to high load capacitance. For the E-TSPC logic circuit, the short-circuit power is the major problem. The E-TSPC circuit has the merit of higher operating frequency than that of the TSPC circuit due to the reduction in load capacitance, but it consumes significantly more power than the TSPC circuit does for a given transistor size. The following analysis is based on the latest design using the popular and low-cost 0.18-μm CMOS process.

A). Sleep Transistor Approach the most well-known traditional approach is the sleep approach [3]. In the sleep approach, both (i) an additional “sleep” PMOS transistor is placed between VDD and the pull-up network of a circuit and (ii) an additional “sleep” NMOS transistor is placed between the pull-down network and GND. These sleep transistors turn off the circuit by cutting off the power rails. By cutting off the power source, this technique can reduce leakage power effectively. However, the technique results in destruction of state plus a floating output voltage.

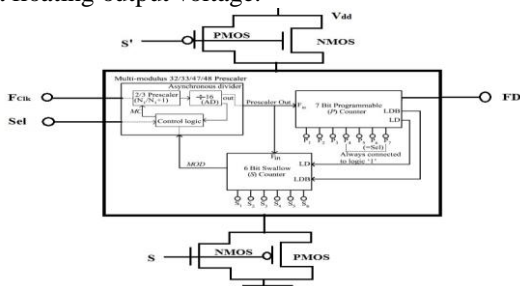

Figure 2. Proposed dynamic logic multiband flexible divider using sleep transistor

B). Dual Stack Approach In dual stack approach [7], 2 PMOS in the pull- down network and 2 NMOS in the pull-up network are used. The advantage is that NMOS degrades the high logic level while PMOS degrades the low logic level. Compared to previous approaches it requires greater area. The delay is also increased.

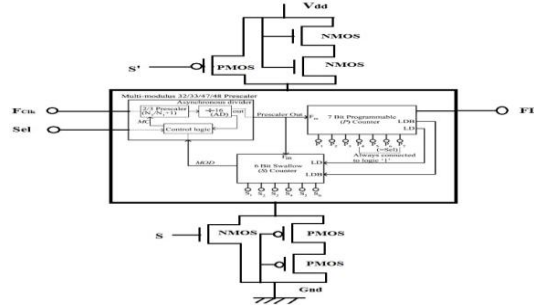

Figure 3. Proposed dynamic logic multiband flexible divider using dual stack

III WIDEBAND 2/3 PRESCALER

The E-TSPC 2/3 prescaler reported in [1] consumes large short- circuit power and has a higher frequency of operation than that of TSPC2/3 prescaler. The wideband single-phase clock 2/3 prescaler used in this design was reported in [2] which consists of two D-flip-flops. Two NOR gates embedded in the flip-flops as in Fig. 4. The first NOR gate is embedded in the last stage of DFF1, and the second NOR gate is embedded in the first stage of DFF2. Here, the transistors M2, M25, M4, M8 in DFF1 helps to eliminate the short-circuit power during the divide-by-2 operation. The switching of division ratios between 2 and 3 is controlled by logic signal MC. The load capacitance of the prescaler is given by

$$C_{L_Design-1} = C_{dbM19} + C_{dbM20} + 2(C_{gdM19} + C_{gdM20}) + C_{gM15} + C_{gM11} \quad (4)$$

When MC='1', transistor M10 turns-on and node S3 switches to logic '0' irrespective of the data at node S2. The second NOR gate output is always equal to the inverted output of DFF2 as shown in Fig., which is equivalent to simple DFF with its complimentary output connected to the input as shown in Fig.. Thus the prescaler act as divide-by-2 when MC='1'. Here, even though the output of DFF2 is connected in feedback to the input of DFF1, the switching data at node S1 and S2 is blocked by the transistor M10 to reach to the node S3. Thus the switching power at the node S3 is always zero and S2 due to the feedback action of the DFF2 output which switches continuously.

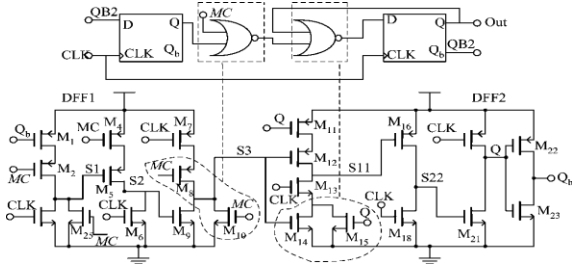

Figure 4. Wideband single phase clock 2/3 prescaler.

The total power of the prescaler in divide-by-2 mode of operation is equal to the sum of switching power of DFF2 and the switching power of first two stages of DFF1 which is less than the conventional 2/3 prescaler.

$$P_{\text{wideband-divide-by-2}} = \sum_{n=1}^4 F_{\text{clk}} C_{\text{li}} V_{\text{dd}}^2 + P_{\text{sc1}} + P_{\text{sc2}} \quad (5)$$

When $MC = '0'$, transistor M10 turns-off and the inverted data at node S2 is passed to the node S3. The second NOR gate output is always equal to the inverted output of DFF2. Fig4, shows the equivalent circuit of the proposed 2/3 prescaler unit in divide-by-3 mode of operation which is equivalent to the schematic shown in Fig5. The combination of inverter and NOR gate is equivalent to logic AND gate with the other input inverted. Thus the prescaler act as divide-by-3 when $MC = '0'$. There is continuous switching activity at each node and the switching power is given by the sum of switching power of both the DFF1 and DFF2 respectively

IV MULTIMODULUS 32/33/47/48 PRESCALAR

The proposed wideband multimodulus prescaler is similar to the 32/33 prescaler but with an additional inverter and a multiplexer. The proposed prescaler can divide the input frequency by 32, 33, 47, and 48 is shown in Fig. 5. It performs additional divisions (divide-by-47 and divide-by-48) without any extra flip-flop, thus saving a considerable amount of power and also reducing the complexity of multiband divider. The multimodulus prescaler consists of the wideband 2/3 ($N1 / (N1 + 1)$) prescaler, four asynchronous TSPC divide-by-2 circuits ($(AD) = 16$) and combinational logic circuits to achieve multiple division ratios. Besides the usual MOD signal for controlling $N / (N + 1)$ divisions, the additional control signal Sel is used to switch the prescaler between 32/33 and 47/48 modes.

I. Case 1: Sel = 0

When $Sel = 0$, the output from the NAND2 gate is directly transferred to the input of 2/3 prescaler and the multimodulus prescaler operates as the normal 32/33 prescaler, where the division ratio is controlled by the logic signal MOD. If $MC = 1$, the 2/3 prescaler operates in the divide-by-2 mode and when $MC = 0$, the 2/3 prescaler operates in the divide-by-3 mode. If $MOD = 1$,

the NAND2 gate output switches to logic "1" ($MC = 1$) and the wideband prescaler operates in the divide-by-2 mode for entire operation. The division ratio N performed by the multimodulus prescaler is

$$N = (AD * N1) + (0 * (N1 + 1)) = 32 \quad (6)$$

Where $N1 = 2$ and $AD = 16$ is fixed for the entire design. If $MOD = 0$, for 30 input clock cycles MC remains at logic "1", where wideband prescaler operates in divide-by-2 mode and, for three input clock cycles, MC remains at logic "0" where the wideband prescaler operates in the divide-by-3 mode. The division ratio $N + 1$ performed by the multimodulus prescaler is

$$N+1 = ((AD-1)*N1) + (1*(N1+1)) = 33 \quad (7)$$

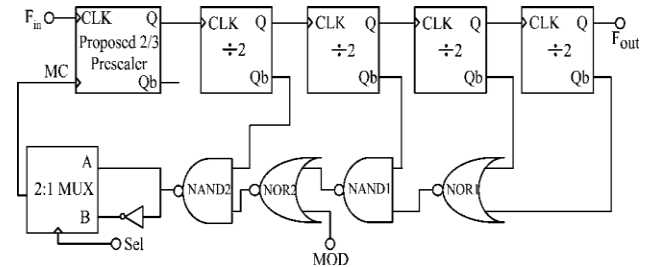

Figure 5. Multimodulus 32/33/47/48 Prescaler.

II. Case 2: Sel = 1

When $Sel = 1$, the inverted output of the NAND2 gate is directly transferred to the input of 2/3 prescaler and the multi-modulus prescaler operates as a 47/48 prescaler, where the division ratio is controlled by the logic signal . If $MC = 1$, the 2/3 prescaler operates in divide-by-3 mode and when $MC = 0$, the 2/3 prescaler operates in divide-by-2 mode which is quite opposite to the operation performed when $Sel = 0$. If $MOD = 1$, the division ratio $N + 1$ performed by the multimodulus prescaler is same as (4) except that the wideband prescaler operates in the divide-by-3 mode for the entire operation given by

$$N+1 = (AD*(N1+1)) + (0*N1) = 48 \quad (8)$$

If $MOD = 1$, the division ratio N performed by the multimodulus prescaler is

$$N = ((AD-1)*(N1+1)) + (1*N1) = 47 \quad (9)$$

V. MULTIBAND FLEXIBLE DIVIDER USING SLEEP TRANSISTORS

The single phase clock multiband flexible divider using sleep transistor which is shown in Fig. 1 consists of the multimodulus 32/33/47/48 prescaler, a 7-bit programmable -counter and a 6-bit swallow counter. The multi-modulus 32/33/47/48 prescaler is briefly discussed

in Section IV. The control signal decides whether the divider is operating in lower frequency band (2.4 GHz) or higher band (5–5.825 GHz).

A. Swallow S-counter

The 6-bit S-counter shown in Fig. 6 consists of six asynchronous loadable bit-cells, a NOR-embedded DFF and additional logic gates to allow it to be programmable from 0 to 31 for low-frequency band and from 0 to 47 for the high-frequency band. The asynchronous bit-cell used in this design uses two additional transistors M6 and M7 whose inputs are controlled by the logic signal **MOD**. If **MOD** is logically high, nodes S1 and S2 switch to logic“0” and the bit-cell doesn’t perform any function. The **MOD** signal goes logically high only when the S-counter finishes counting down to zero. If **MOD** and **LD** are logically low, the bit-cell acts as a divide-by-2 unit. If **MOD** is logically low and **LD** is logically high the input bit **PI** transferred to the output.

B. Programmable P-counter

The programmable P-counter used in the design of the fully programmable divider is a 7-bit asynchronous down counter. The P-counter is designed with 7 reloadable TSPC D flip-flops (DFF) and an end-of-count (EOC) detector which has reload circuit in it. Since the counter is asynchronous and based on the ring topology, the complementary output of the first DFF is fed as clock to the input of next flip-flop. In the initial state, all the reloadable FF’s are loaded by the programmable pins **P1-P7**. As the counter is triggered by the output of the prescaler, the **P**-counter starts down counting till the state “0000000” is reached. Once this state is detected by the EOC logic circuit, the load (**LD**) signal goes high to reset all loadable FF’s to the initial state. The 32/33 prescaler scales the input 2.4 GHz signal by a value of 32 or 33 such that the **P** and **S** counters will be working in the frequency range of 72 - 78 MHz in order to obtain the 1 MHz frequency output.

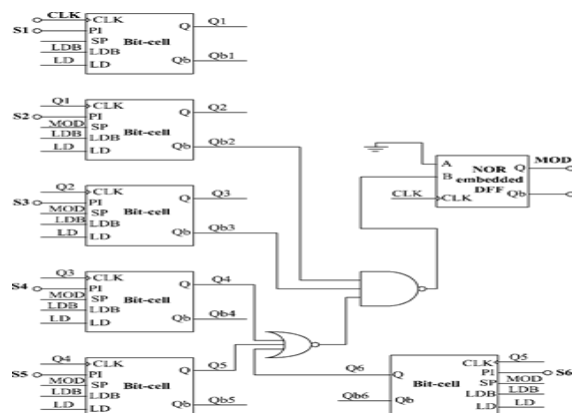

Figure.6. Asynchronous 6-bit S counters

III. RESULTS AND DISCUSSION

The simulation of the design is performed using HSPICE. The proposed multiband flexible divider consume the power consumption, gate count and area of the previous programmable dividers and the proposed programmable divider at the supply voltage shown in Table

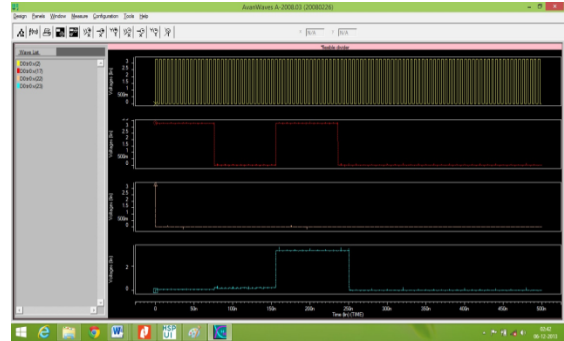

Figure.10. simulation wave forms of sleepyP

Table.3.PERFOMANCE OF DIFFERENT DIVIDERS

Refer ence	Previous divider	Present sleepy	Sleepy approach	Dual stack
Power (mW)	4.32e-03	1.23e-03	2.19e-03	2.73e-03
Delay	1.004n	1.006n	1.022n	1.009n
P.D.P	4.34e-12	1.24e-12	2.24e-12	2.75e-12

Comparison between previous and present work and power delay product was calculated.

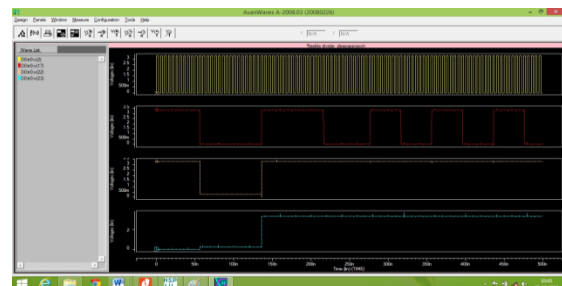

Figure.12. simulation wave forms of sleepy approach

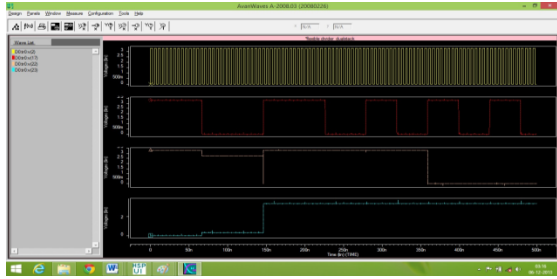

Figure.13. simulation wave forms of dual stack

Table.1.PERFOMANCE OF DIFFERENT DIVIDERS

Reference	[5]	[4]	Previous work	Present Work sleepyP
Process(μm)	0.18	0.25	0.18	0.18
Supply voltage(v)	1.0	1.8	1.8	3.3
Power (mW)	2.7	6.25	0.96	1.236e-03

Table.2.PERFOMANCE OF DIFFERENT DIVIDERS

Reference	SleepyN	Sleepy approach	Dual stack
Process(μm)	0.18	0.18	0.18
Supply voltage(v)	3.3	3.3	3.3
Power (mW)	1.328e-03	2.191e-03	2.732e-03

Comparison between previous work and present work we can reduce the power consumption and reduce the 7 number of stages

IV. CONCLUSION

In this paper a lower-power single-phase clock multiband flexible divider with sleep transistor, the circuit simplicity leads to reduced power consumption, reduced number of gates required and hence a reduced area requirement we have implemented fully programmable multi-band flexible divider for Bluetooth, Zigbee, IEEE 802.15.4 and 802.11 a/b/g frequency synthesizers. However, implementing frequency synthesizer which covers 2.4 GHz ISM band and 5-6 GHz WLAN using multi-band divider is very challenging as it requires low power, low phase noise dual-band VCO. When compared to previous power consumption 56.74% has been reduced. In future, more work has to be done in exploring better ways of implementing the low power techniques.

V. ACKNOWLEDGMENTS

The author would like to thank prof. Divya Meshram and prof. M. Vyawahare and my Parents for their help, support, valuable discussion and suggestions.

REFERENCES

- [1] Vamshi Krishna Manthana, Manh Anh Do, Chirn Chye Boon, and Kiat Seng Yeo., "A Low-Power Single-Phase Clock Multiband Flexible Divider", IEEE Trans. Very Large Scale Integr. (VLSI) Syst., vol. 20, no. 2, Feb. 2012
- [2] Yin-Tsung Hwang and Jin-Fa Lin., "Low Voltage and Low Power Divide-By-2/3 Counter Design Using Pass Transistor Logic Circuit Technique", IEEE Trans. Very Large Scale Integr.(VLSI) Syst., vol. 20, no. 9, Sep. 2012
- [3] S. Mutoh et al., "1-V Power Supply High-speed Digital Circuit Technology with Multithreshold-Voltage CMOS," IEEE Journal of Solis-State Circuits, Vol. 30, No. 8, pp. 847-854, August 1995.
- [4] S. Pellerano et al., "A 13.5-mW 5 GHz frequency synthesizer with dynamic-logic frequency divider," IEEE J. Solid-State Circuits, vol. 39, no. 2, pp. 378-383, Feb. 2004.
- [5] S. Vikas et al., "1 V 7-mW dual-band fast-locked frequency synthesizer," in Proc. 15th ACM Symp. VLSI, 2005, pp. 431-435.
- [6] X. P. Yu et al., "Design and optimization of the extended true single-phase clock-based prescaler," IEEE Trans. Microw. Theory Tech., vol. 56, no. 11, pp. 3828-3835, Nov. 2006.